

# **WX5025 Datasheet**

**2024.8**

## 申明

位

位

位



**REVISION HISTORY ..... 3**

**) OP ( ..... 1**

) )

) ) )

) )



➤

) )

- H 0( )I !
- =LK 0( )IYr!
- I F 0( )IY !
- N=H9
- =L9
- EA: EGF
- NPD9F ]f] ] FN =

) ) +

- AH L H K
- G=
- L H C:
- Dafck][
- AHK][
- AH L H M<H KL H
- 了 M<H
- 
- ND9F LY\_
- 优 E9 ND9F
- 

) )

- EKA EKA%P
- 了
- L H
- LH D A<G 9 A NH< = 9= N<E
- ) : )C:
- H A=
- << <+ 9 HA

) )

- K %AGN
- ) 0 优
- +
-

- ) 0
- DDA
- 
- +
- ) 0 E9
- (1 了
- (1 了
- 

) )

- 
- H A] ]f p) p p p0
- D9F 0 HAG
- D9F ) AA
- KHA
- M9 L
- F KA
- 0 HAG
- KE k
- 

)

			但















	了



---



	( 1	) (	) (	N
	( 1	) (	) (	N
	( 0	( 1	( 1	N
	(	( 0	( 0	N
	)	) 0	) 10	N
	( 0	( 1	( 1	N
	)	) 0	) 10	N

) +

	Min	Typ	Max	Units	Ripple
	(		(	z	
	) )	) 0	) 01	N	( eN
	) )	) 0	) 01	N	( eN
	) )	) 0	) 01	N	( eN
	) )	) 0	) 01	N	( eN



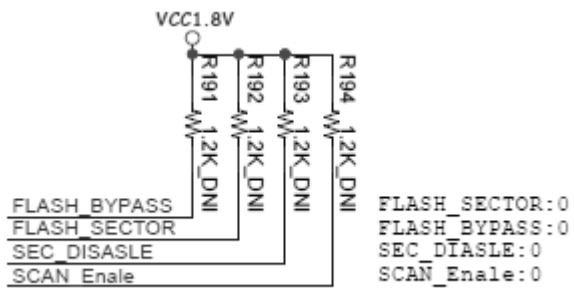
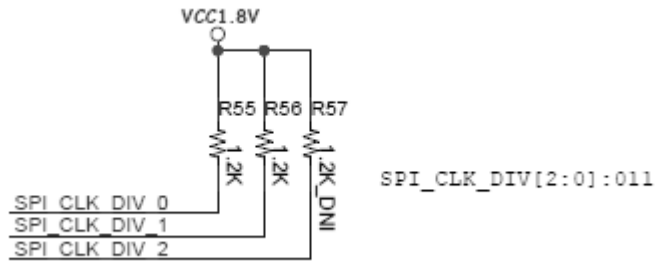

串

) + =L

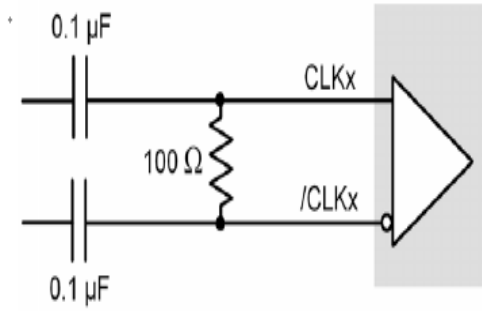

) +

OP ( H A= ( 1N ) ON ( ON ( 1N ) ( N ) ON ) ( N ) ON D<G  
 =L =L (WN<<9W AGW E =L )WN<<9W AGW E H Q  
 =L =L )WN<<9W G =W E P =L )WN<<9W G =W E P H Q  
 =L =L (WN<<<W G =W9F9W P =L )WN<<<W G =W9F9W P H Q  
 串 H Q H=WH QWNH ( 1N  
 个 H=WH QWNH TN<<9)0 ) ON 个  
 : DE)OH +( (KF) ) (f T) ((f T T) ( ( 1N  
 ) 9 ( 1N 9 ) (0  
 ) ON ) ( N 9 D<G

) +

	Min	Typ	Max	Units
LHMW =K=L =K=L !	) (			ek
L =K=L	) (			ek

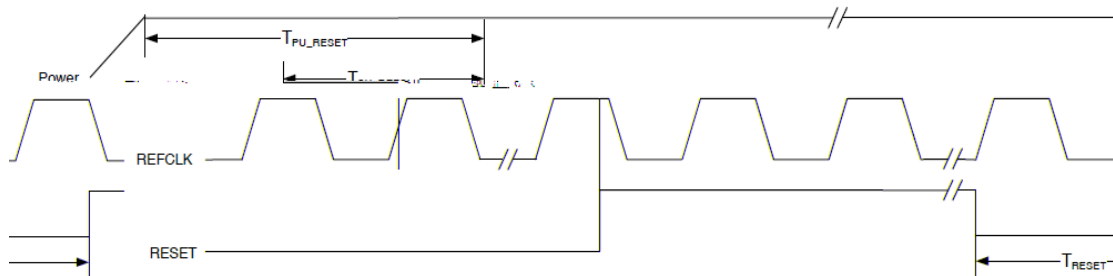

) + 0 F KA 9 Kh][ a a[Y agf

Symbol	Parameter	Min	Typ	Max	Units
L[c	F KAW = W DC j]i ]f[q		(		E r
\[	F KAW = W DC \ q [q[d]	+			
Y[[	F KAW = W DC Y[[ jY[q			))((	hhe
L[g	dg[c% g%g )( h [ dgY\ ( h ! F KAW P<S) (U F KAW K W<N <Y Y Yda\ jge F KAW = W DC jakaf_ ]\[_]	+			fk
Lk	F KAWLP<S) (U F KAWLPW=F <Y Y K] h g F KAW DCWAF jakaf_ ]\[_]	+			fk
L gd\ L	F KAWLP<S) (U F KAWLPW=F ) <Y Y gd\ jge F KAW = W DC jakaf_ ]\[_]				fk
Lgj	F KAW P<S) (U F KAW K W<N G h Lae] jak]	(			fk
Lg	F KAW P<S) (U F KAW K W<N G h Lae] Ydd	(			fk
L[cj L[c	F KAW = W DC ak] Ydd Lae]	(		+	fk

) + 1 D9K

Manufacturer	Model type
c N	2
T	2
SM Qb Q	0

KHA D9K

) + )(

Manufacturer	Part Number	Model type
R		

) + )) H AW=phj]kk

- H AW=phj]kk + hk
- ↑ (
- +ead
- +0
- LP P
- H A= ( =E
- H A= LP P 0 g e )( (g e )(
- H A= =E ( K][ agf )) 9\\%af Yj\ DYqg ]i aj]e]f k Yf\ ]][gee]f\Y agfk

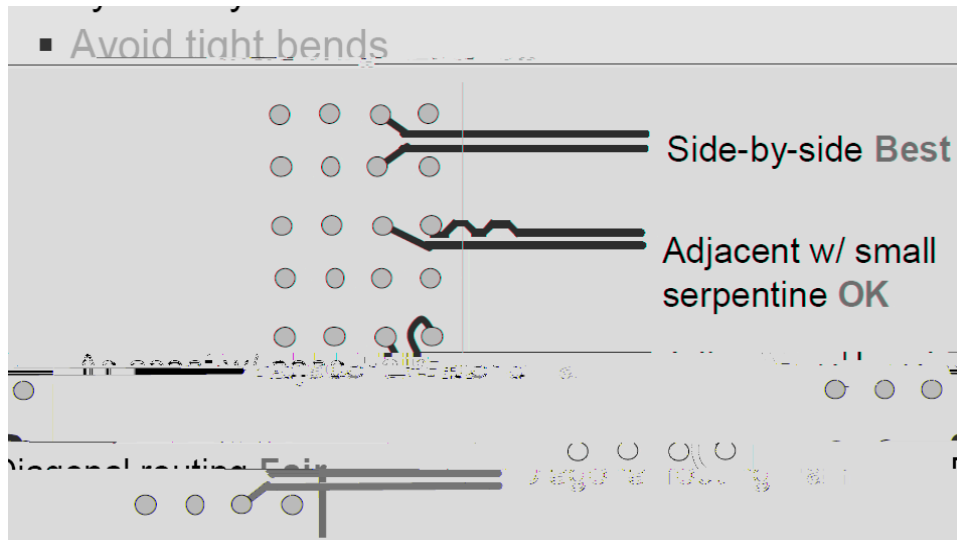

) + ) K H

- K H K HW P K HWLP ead (ead )( ( LP P

- K A LP P k

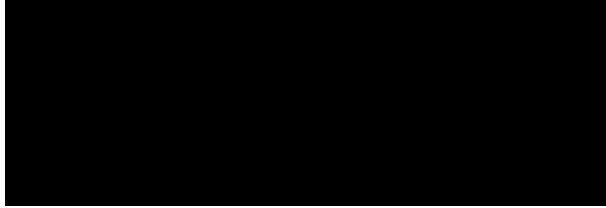

- K H N + +N )9
- K H
- K A LP P

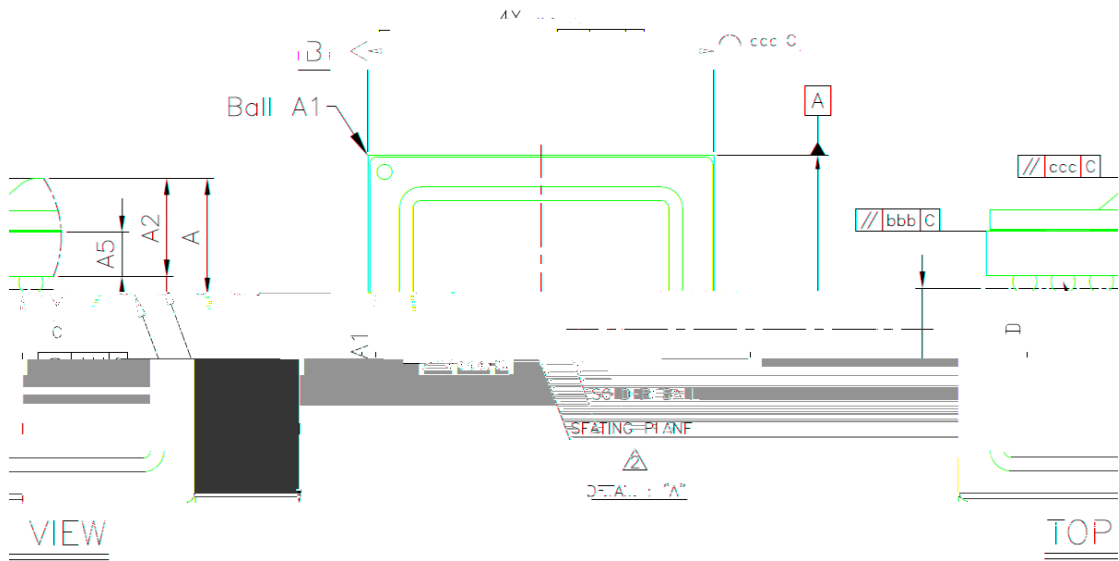
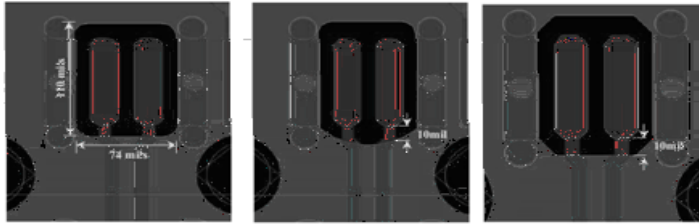

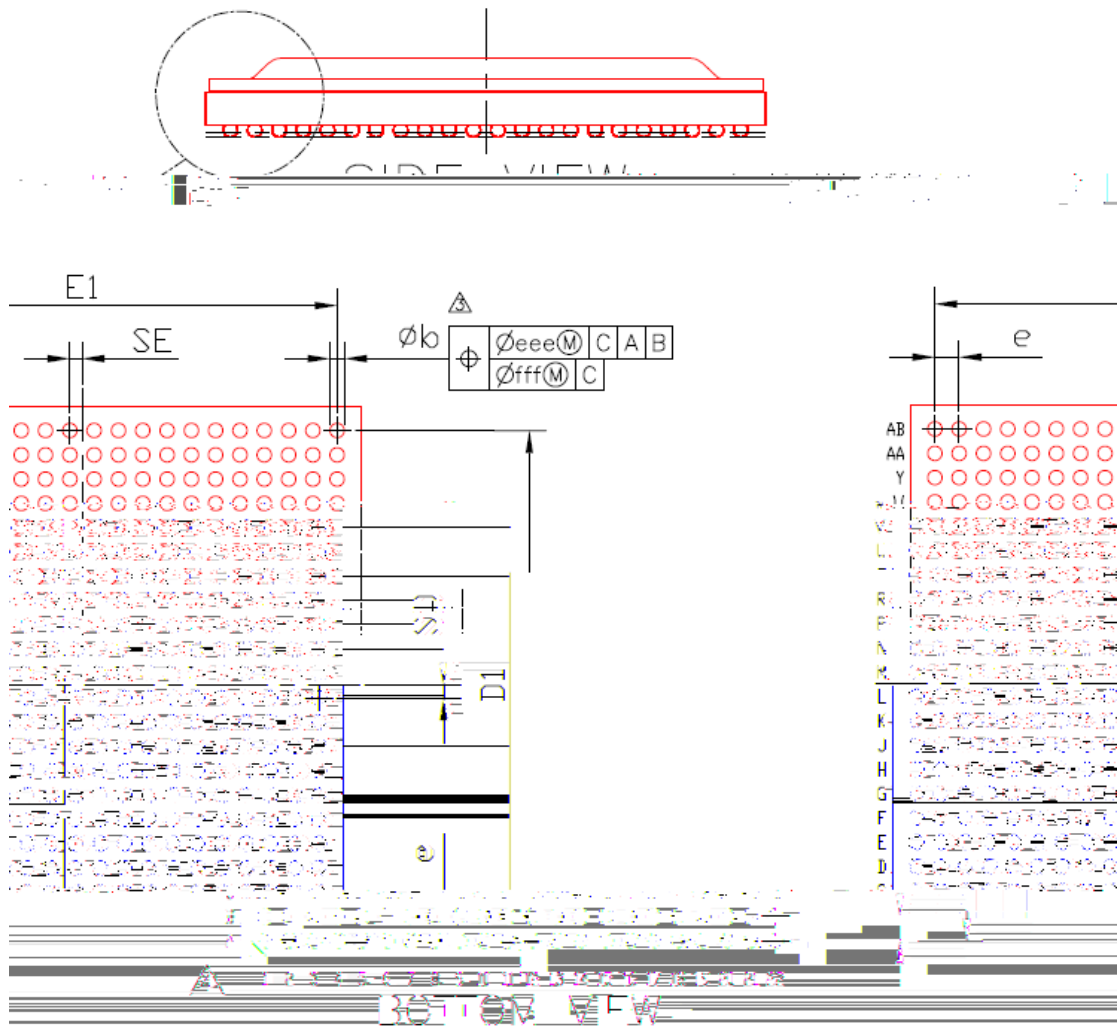



Symbol	Dimension in mm			Dimension in inch		
	MIN	NOM	MAX	MIN	NOM	MAX
A	3.024	3.254	3.484	0.119	0.128	0.137
A1	0.390	0.490	0.590	0.015	0.019	0.023
A2	2.620	2.764	2.908	0.103	0.109	0.114
A5	1.219	1.354	1.489	0.048	0.053	0.059

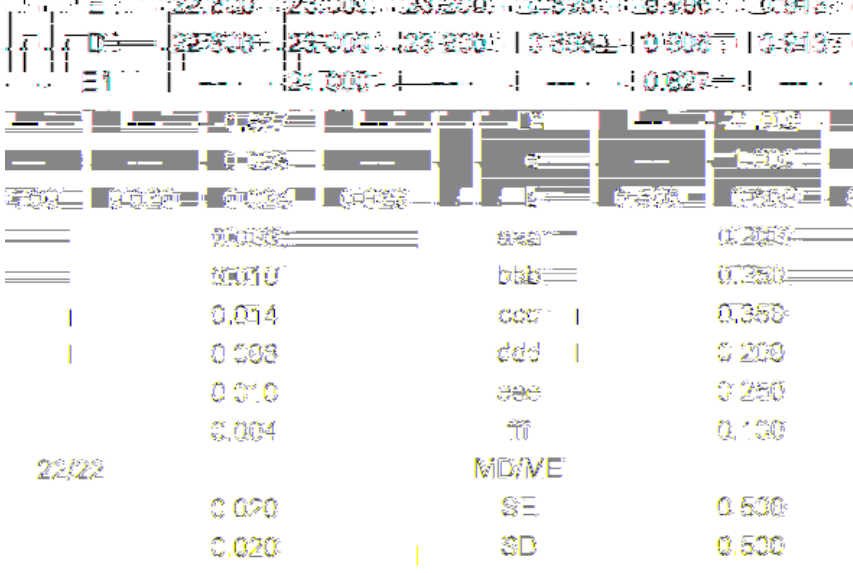

+

+ )

串 z

0